

APPLICABLE STANDARDS:

Design : API 609
 Rating : CLASS 150 - 600
 Face to Face : API 609
 End Flanged : ASME B16.5
 Inspection & Testing : API 598
 Wall Thickness : ASME B16.34
 Temperature : -29°C ~ +425°C

⦿ All other design standards are available on request.

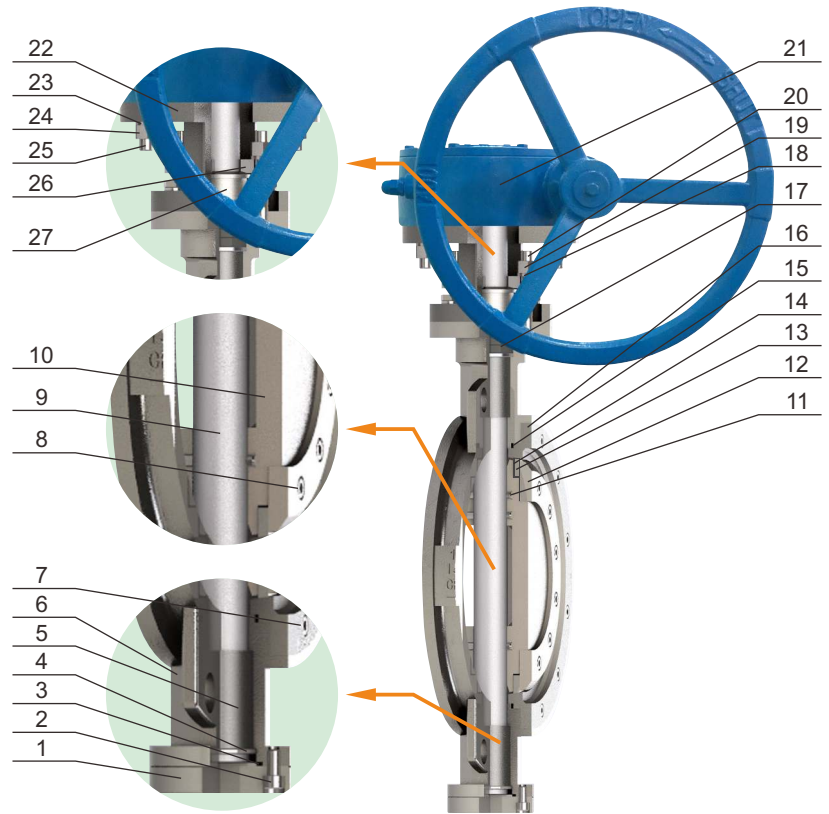

» MATERIAL OF CONSTRUCTION

Item	Component	Carbon Steel	Stainless Steel
1	Bottom End Cap	A105	F304 / F316
2	Bolt	8.8	A2-70
3	Bottom End Cap Gasket	304SS+Grafoil	
4	Split Collar	304	
5	Sleeve	316+QPQ	
6	Body	WCB	CF8 / CF8M
7	Bolt	A2-70	
8	Bolt	A2-70	
9	Stem	17-4PH	
10	Disc	WCB	CF8 / CF8M
11	Pin	329	
12	Disc Pressure Ring	A105	F304 / F316
13	Seal Ring	316 / 17-4PH / 316+STL	
14	Disc Gasket	304SS+Grafoil	
15	Body Gasket	304SS+Grafoil	
16	Seat	316+STL	
17	Stem Packing	Grafoil	
18	Washer	SUS301	
19	Bolting Nut	8	A2-70
20	Bolt	8.8	A2-70
21	Gearbox	Molectron	
22	Yoke	WCB	
23	Washer	SUS301	
24	Bolting Nut	8	A2-70
25	Bolt	8.8	A2-70
26	Gland Flange	WCB	CF8 / CF8M
27	Gland	A105	F304 / F316

Dimensions and Weight

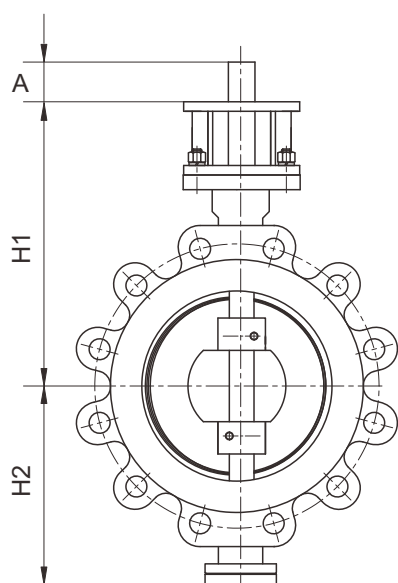

Lug Type

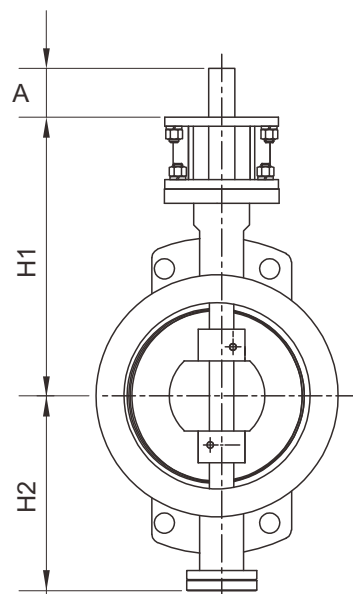
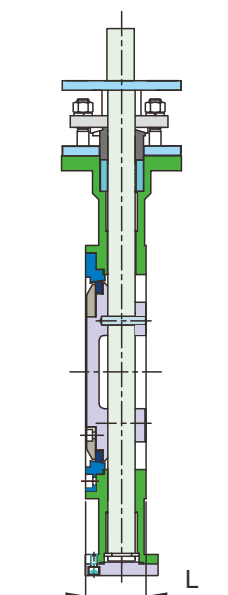

Wafer Type

Unit : mm

SIZE	Lug type ASME CL. 150 (KB-MS331)					Wafer type ASME CL. 150 (KB-MS371)				
inch	H1	H2	A	L	Weight (kg)	H1	H2	A	L	Weight (kg)
3"	260	125	36	48	13	260	125	36	48	10
4"	290	141	36	54	17	290	141	36	54	15
6"	330	165	40	57	23	330	165	40	57	20
8"	385	214	40	64	36	385	214	40	64	34
10"	425	243	40	71	49	425	243	40	71	45
12"	490	286	56	81	83	490	286	56	81	73
14"	525	312	56	92	117	525	312	56	92	97
16"	545	350	80	102	160	545	350	80	102	123
18"	580	383	80	114	194	580	383	80	114	164
20"	580	414	80	127	270	580	414	80	127	220
24"	690	484	140	154	387	690	484	140	154	324

Unit : mm

SIZE	Lug type ASME CL. 300 (KB-MS332)					Wafer type ASME CL. 300 (KB-MS372)				
inch	H1	H2	A	L	Weight (kg)	H1	H2	A	L	Weight (kg)
3"	260	125	36	48	18	260	125	36	48	14
4"	290	141	36	54	22	290	141	36	54	15
6"	350	189	40	59	41	350	189	40	59	29
8"	415	236	56	73	56	415	236	56	73	50
10"	455	272	56	83	77	455	272	56	83	75
12"	490	310	80	92	119	490	310	80	92	109
14"	545	335	80	117	254	545	335	80	117	164
16"	575	389	140	133	300	575	389	140	133	228
18"	660	422	140	149	455	660	422	140	149	285
20"	700	462	140	159	499	700	462	140	159	343
24"	785	531	160	181	788	785	531	160	181	513

Unit : mm

SIZE	Lug type ASME CL. 600 (KB-MS333)					Wafer type ASME CL. 600 (KB-MS373)				
inch	H1	H2	A	L	Weight (kg)	H1	H2	A	L	Weight (kg)
3"	234	136	40	54	24	234	136	40	54	20
4"	298	185	40	64	25	298	185	40	64	21
6"	355	238	56	78	49	355	238	56	78	41
8"	405	263	80	102	84	405	263	80	102	70
10"	485	328	140	117	126	485	328	140	117	105
12"	538	365	140	140	183	538	365	140	140	153
14"	610	390	140	155	276	610	390	140	155	230
16"	680	440	160	178	383	680	440	160	178	319
18"	683	460	160	200	478	683	460	160	200	399
20"	795	526	200	216	576	795	526	200	216	480
24"	885	623	200	232	861	885	623	200	232	718